

VCE Rotary Vertical Carton Erector

Touch screen controls

Easy accessibility

Small footprint

Rotary carton setup

Standard Features

- Rotary head timing belt drive for low maintenance
- Heavy duty aluminum support plates
- Speeds up to 100 cpm, product dependent
- PIAB vacuum generator
- 48-inch power-fed magazine
- Quick changeover
- Variable speed drive
- Touch screen controls

Optional Features

- Pre-opener for square cartons
- Laser printer
- Bar code scanner-verification-reject chute
- Casters for portability
- Servo drive
- Extended magazine
- Stainless steel construction

Ask us about testing your product



"YOUR PARTNER IN AUTOMATED PACKAGING™"

PACKAGING SYSTEMS AUTOMATION, INC.
Packaging Equipment and System Specialists

VCE Rotary Vertical Carton Erector



Heavy-Duty Components. From the low-maintenance timing belt drive to the aluminum support plates, the PSA VCE is built for long-lasting performance.

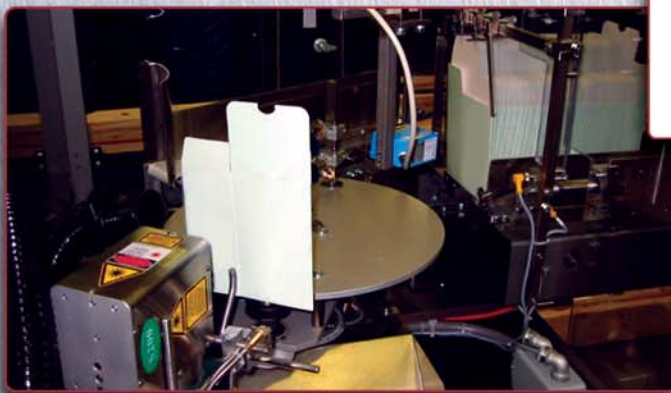

Process Enhancement Options. VCE options include integrated bar code scanner and laser printer.

Carton Erector for Auto-Bottom Cartons

Rotary set-up, speeds up to 100 cpm, 48-inch power-fed magazine, touch-screen control panel, variable-speed drive, PIAB vacuum generator.

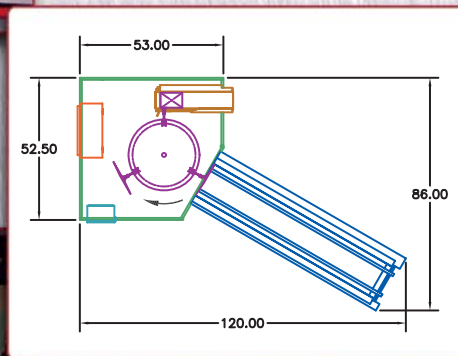

Expanded size ranges available to meet your requirements

Machine Range

Min-Max	Length	Width	Height
MIN	3.75"	2.5"	6"
MAX	8"	5.5"	10"



"YOUR PARTNER IN AUTOMATED PACKAGING™"

PACKAGING SYSTEMS AUTOMATION, INC.

Packaging Equipment and System Specialists

2200 Niagara Lane, Plymouth, MN 55447

PHONE: 763-473-1032 FAX: 763-473-1204

www.psautomation.com EMAIL: sales@psautomation.com